

| Table 1. Specifications (Pump) | | |
|---------------------------------------|--|---|
| Pump | Model | QP-3TH |
| | Type | Trash Pump |
| | Suction & Discharge Size | 3.00 in. (76 mm.) |
| | Maximum Pumping Capacity | 396 gallons/minute (1,500 liters/minute) |
| | Max. Solids Diameter | 1.50 in. (38 mm.) |
| | Max. Head | 95 ft (29 meters) |
| | Max. Pressure | 41 psi (2.8 bar) |
| Dimension (L x W x H) | 28.7 x 21.7 X 23.0 in. (730 X 550 X 585 mm) | |
| Dry Net Weight | 142 lbs. (54.5 Kg.) | |

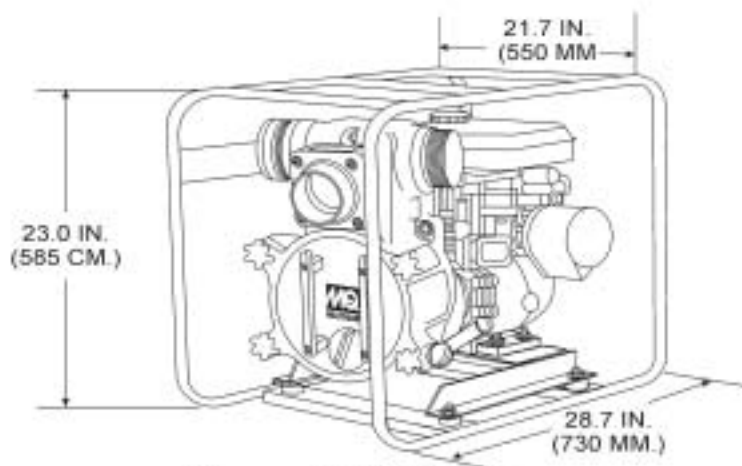
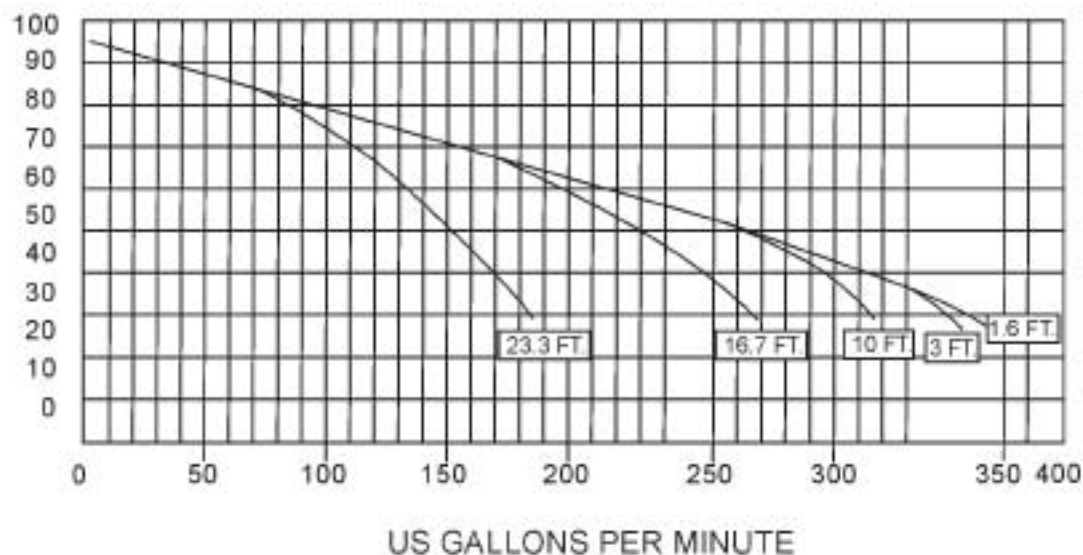

Figure1. QP-3TH Dimensions